

Recommended installation instructions for aluminium sliding doors

The following pages show a number of typical door building-in details and coupling arrangements, if the information you require is not covered in these pages contact your local Vantage fabricator.

Fix the door to structure with steel building-in lugs or nails, shim as indicated.

Installation of sliding doors to be in accordance with Australian Standard AS 2047.

Suggested installation steps:

1. If flashing is required fit the flashing to sill.
2. Fit shims on sill plate / slab on meeting stile centre line and at 300mm maximum centres. Make sure these shims are level.
3. Install the frame into the opening.
4. Fit shims on jambs making sure that frame is plumb and square, measure frame across diagonals to check for square.
5. Fix the frame to structure by nailing through timber reveals, Make sure that frame is not twisted.
Alternative - On solid brick construction fit galvanised M.S. building-in lugs at 450mm maximum centres.
6. Take care that head, sill and/or jamb are not dished or bowed during installation.
7. Sliding door sills are not strong enough to carry wheel barrows. Protect the sill with timber ramps to protect them from damage during construction.
8. Cement mortar droppings can permanently damage aluminium. Remove cement as soon as possible.
9. Leave at least 10mm gap between sill brick and frame to allow for possible future building settlement.
10. On brick veneer construction there should be at least a 12mm gap between timber header and aluminium frame.
11. Aluminium door frames are not designed to support eaves linings.

Important Note:

If you install door frames and/or panels out of square or without sufficient shims the doors won't perform correctly.

Installing Frame

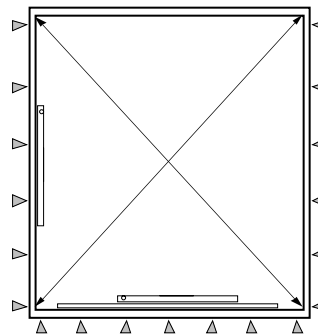

Check measure diagonals during installation

Building-in lugs at approx. 450mm maximum centres

Locate one lug at lock keeper position

It's critical that sill is installed level. Use spirit level on straight edge

Shim sill as required to obtain level at 300mm approx. centres

Check Door Panels

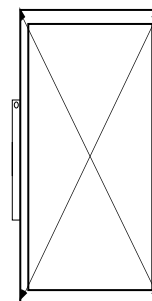

Check measure diagonals before installing door panels into the frame.

Check that door panel stiles are plumb and level before installing panels into frame.

Install Panels into Frame

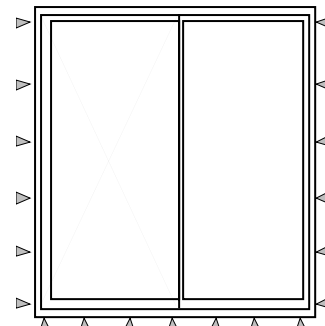



Door Building-in Detail

250mm Brick Veneer with Timber Floor

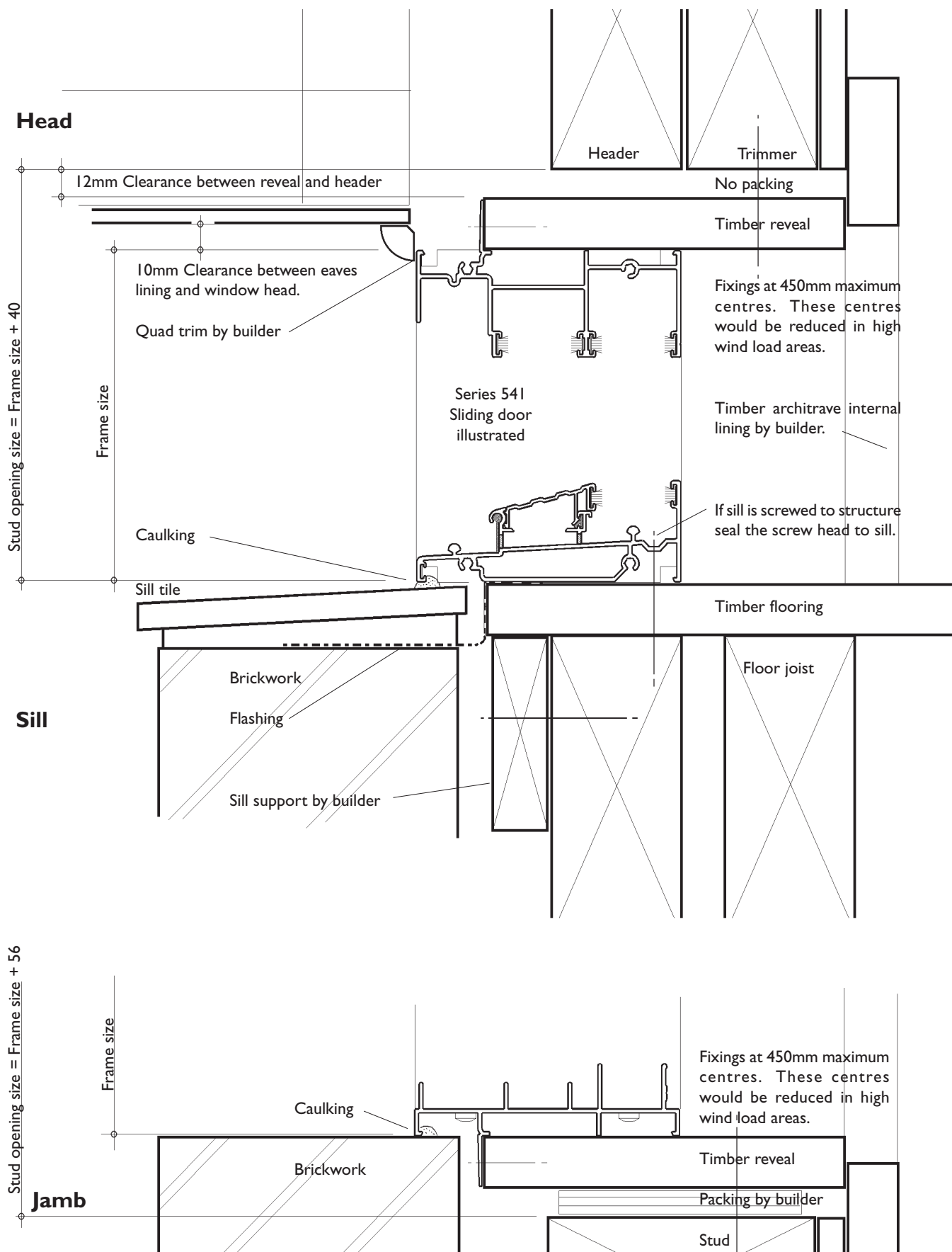



Door Building-in Detail

250mm Brick Veneer with Hardwood Sill

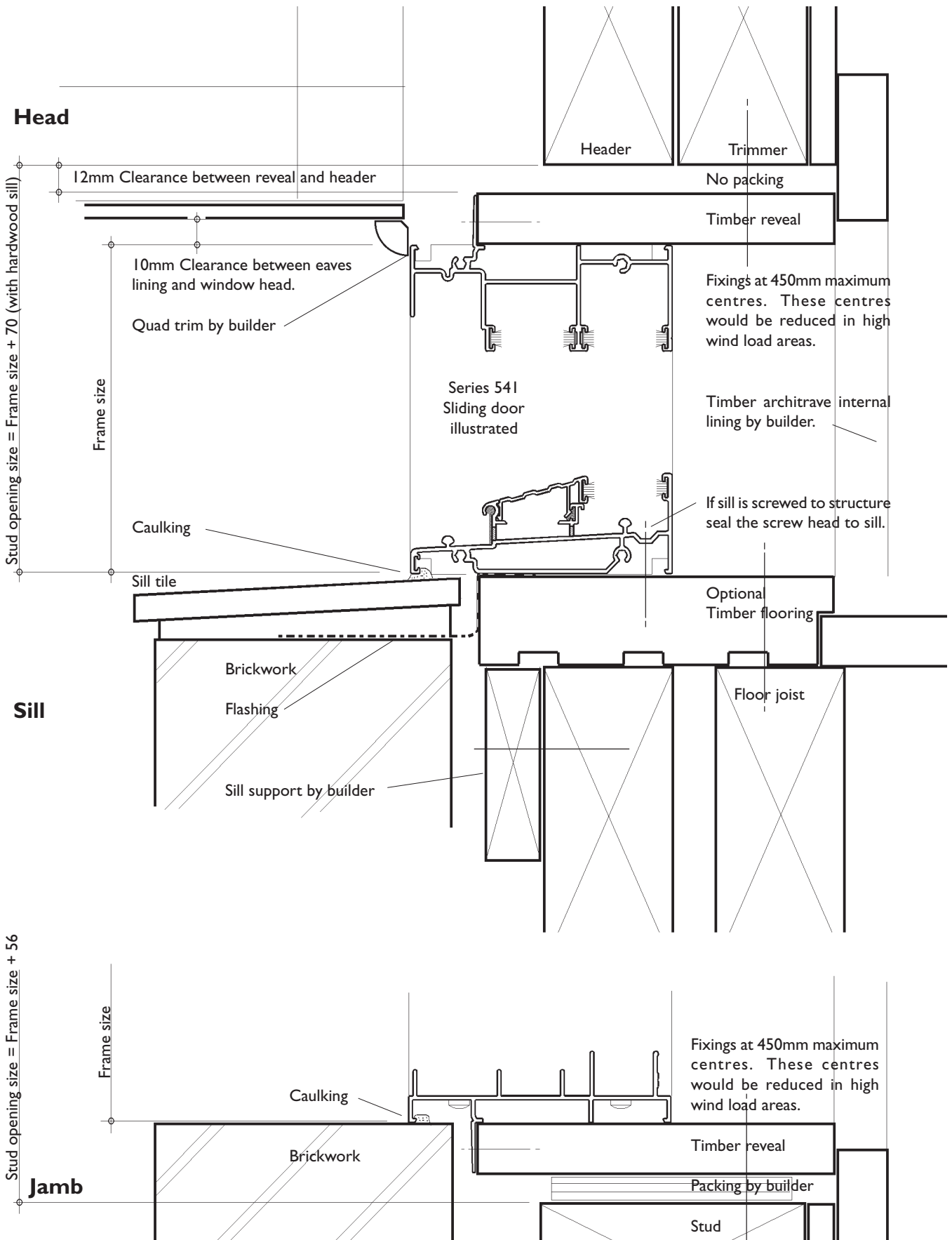

For the latest building-in details refer our web site: www.vantagealuminium.com.au



Door Building-in Detail

250mm Brick Veneer with Concrete Floor Slab

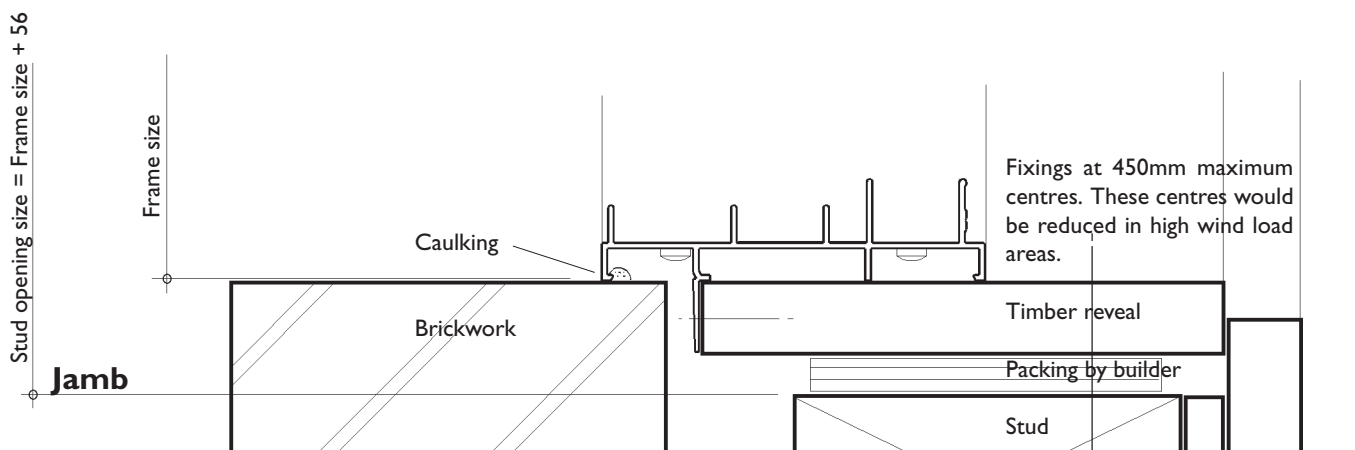
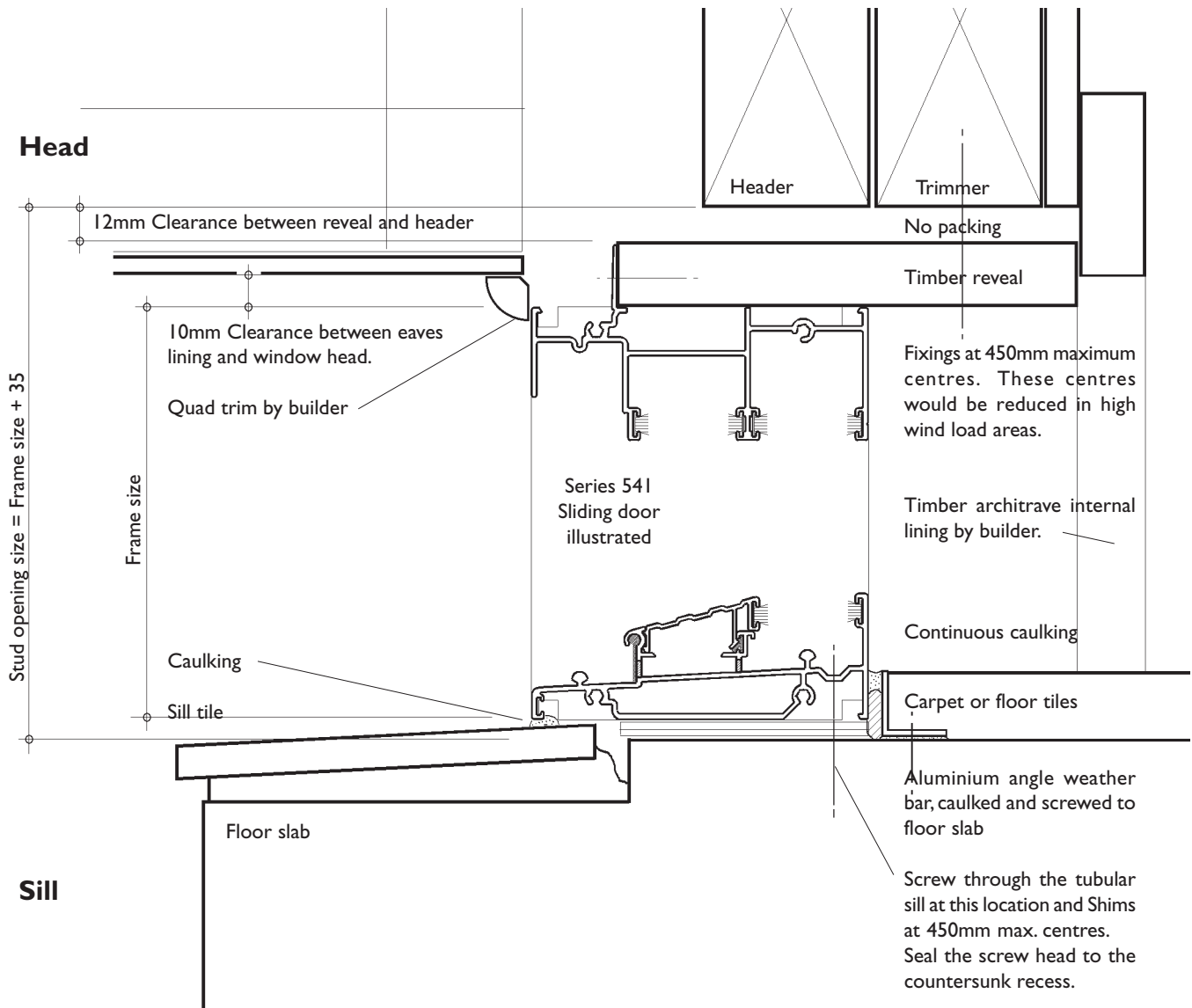

For the latest building-in details refer our web site: www.vantagealuminium.com.au



Door Building-in Detail

Date: Aug 03

250mm Brick Veneer with rebated Concrete Floor Slab

Replaces:

Scale: Half full size

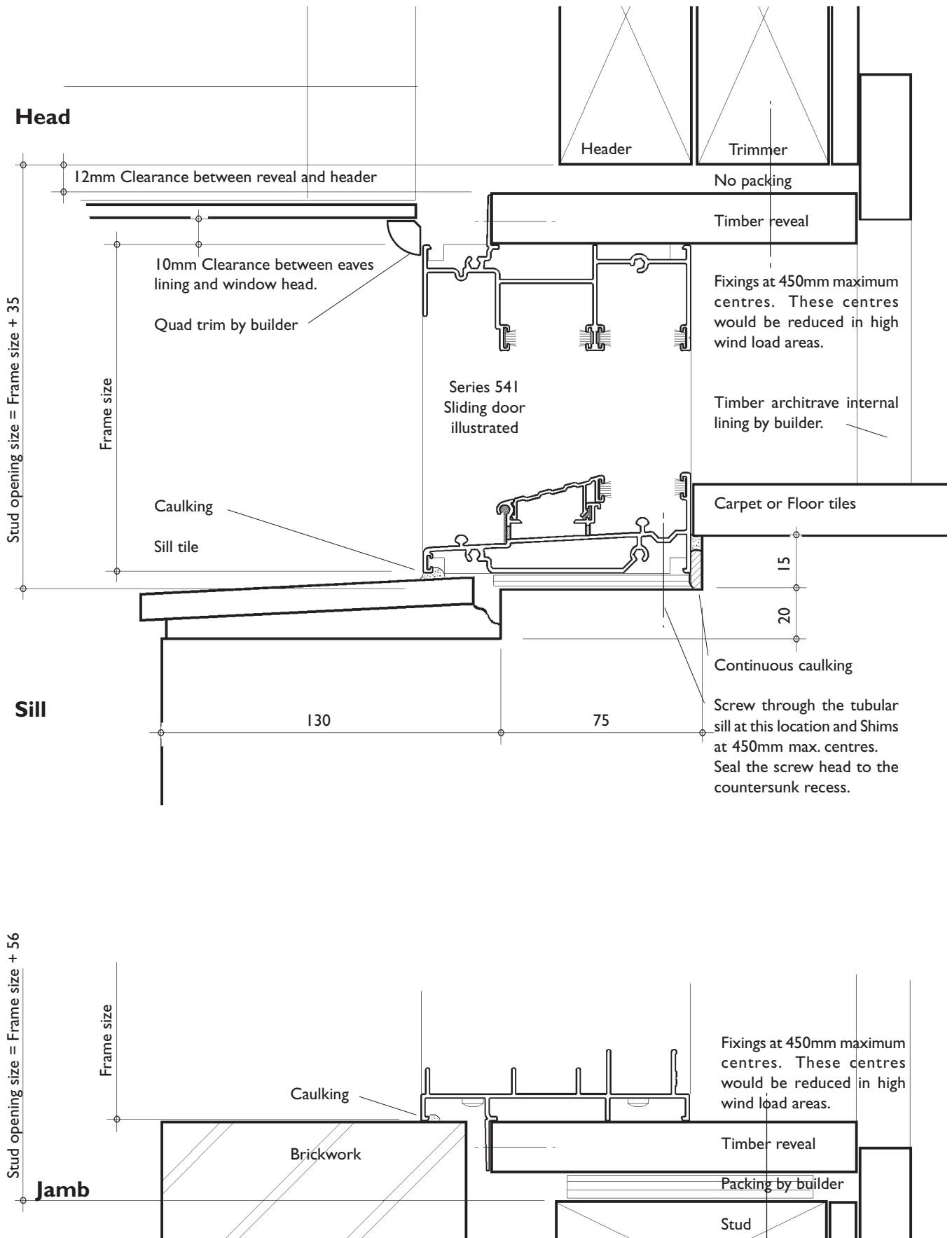

For the latest building-in details refer our web site: www.vantagealuminium.com.au

Architectural Information

Door Building-in Detail

280mm Cavity Brick with Rebated Concrete Floor Slab

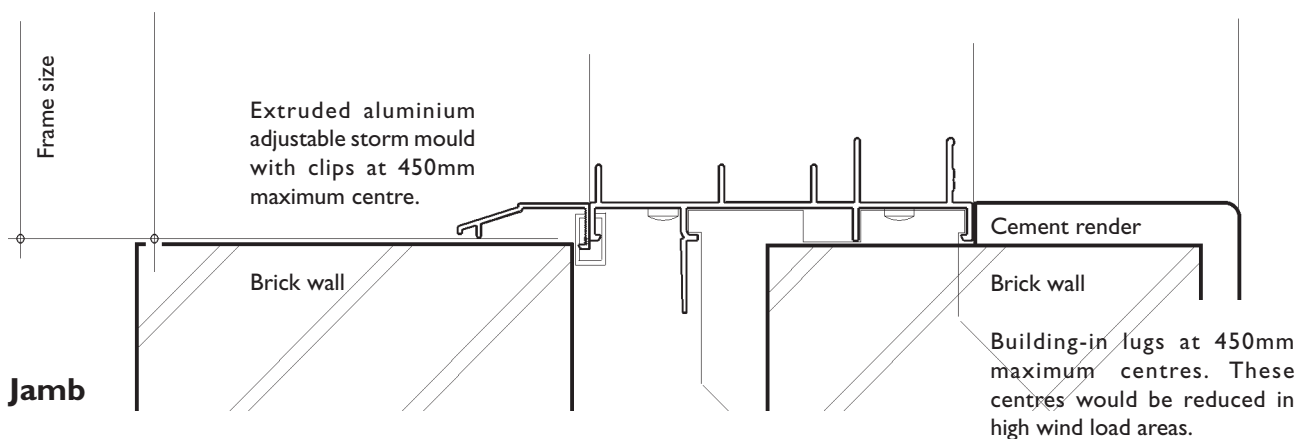
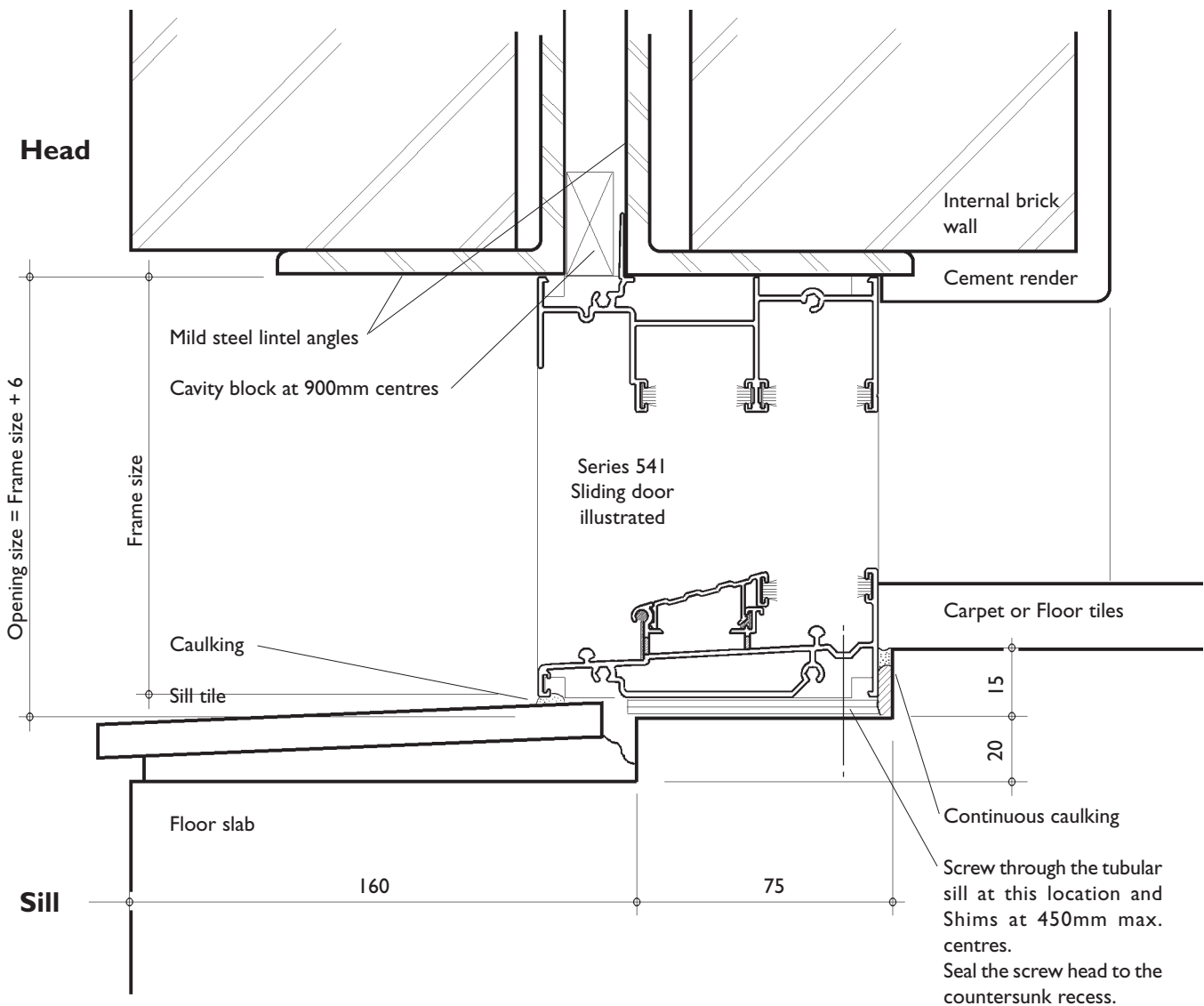

For the latest building-in details refer our web site: www.vantagealuminium.com.au



Door Building-in Detail

280mm Cavity Brick with Rebated Concrete Floor Slab

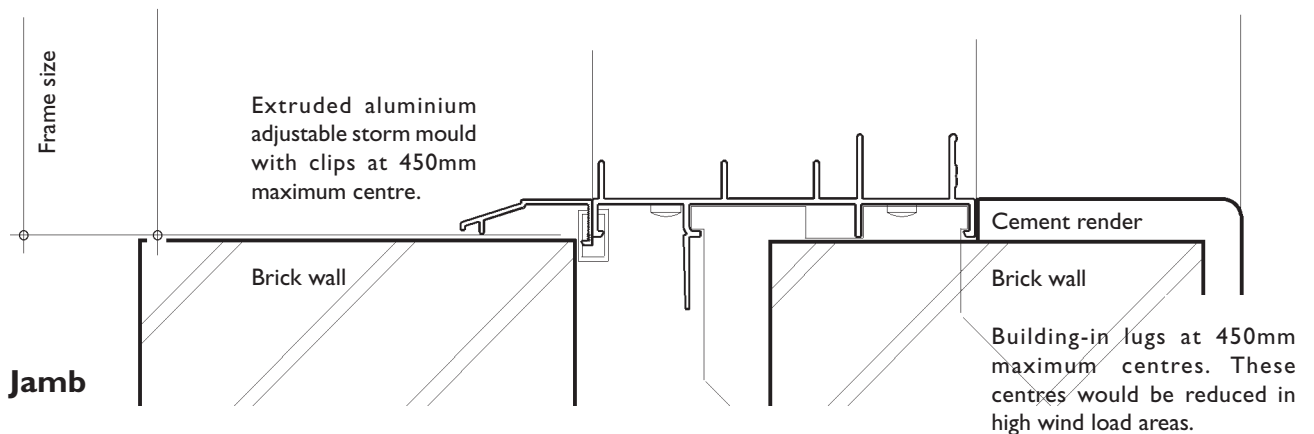
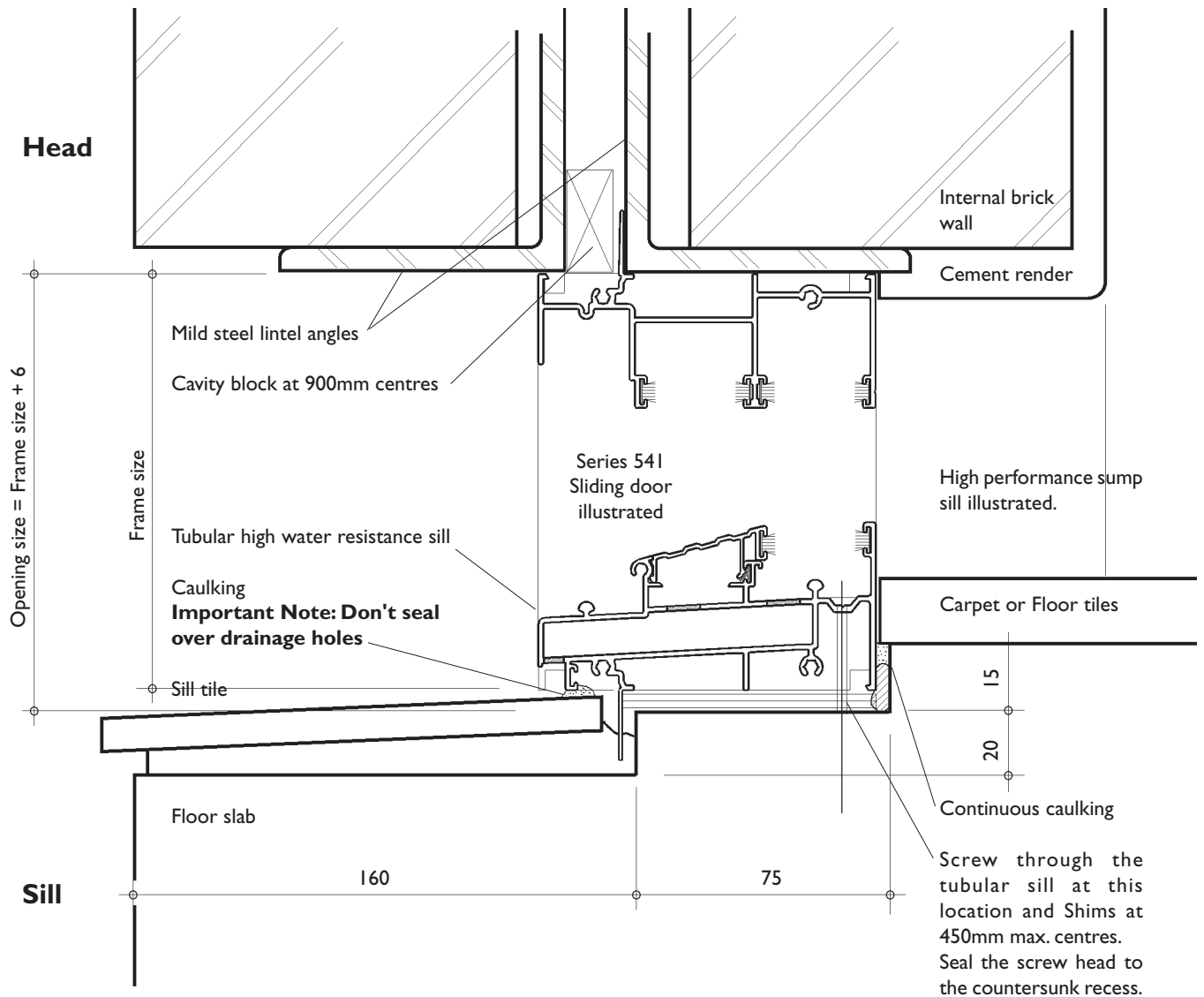

For the latest building-in details refer our web site: www.vantagealuminium.com.au